

# CICARÉ 7B

Single seat light helicopter



## CICARÉ 7B

## TECH SPECS

Seats 1

### ENGINE

Manuf./model Rotax 912 ULS

Type 4 Cyl. boxer

Maximum power 100 HP

### WEIGHT

Empty 265 Kg - 584 lbs

MTOW 430 Kg - 948 lbs

### PERFORMANCE

Max speed VNE 194 Km/h - 104 kt

Cruise speed 150 Km/h - 81 kt

Vertical speed 7 m/s - 1400 ft/min

Service ceiling 3000 m - 9842 ft

**Fuel type** Mogas RON 95 E10 /

AvGas UL91/UL94

**Endurance** 2,5 hrs.

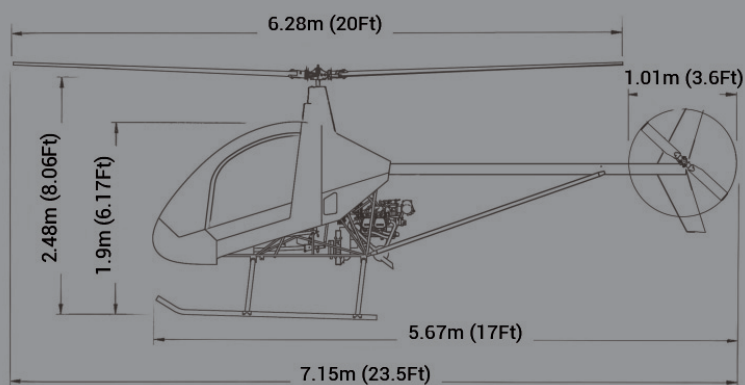

## Father of ultra light helicopters

The **CICARÉ 7B** is a single seat light helicopter for sport and recreational use. It is an evolution of the CH-7 Angel with a notable increase in performance and safety due to the robust and reliable 4-stroke engine Rotax 912 100Hp.



**Operators:** Argentina, Australia, Brasil Canada, Arab Emirates, Eslovakia, USA, Taiwan, Spain, France, Turkey.