

CICARÉ 7BT

Single seat light helicopter



CICARÉ 7T

TECH SPECS

Seats	1
ENGINE	
Manuf./model	Rotax 914 UL
Type	4 Cyl. boxer
Maximum power	115 HP
WEIGHT	
Empty	280 Kg - 617 lbs
MTOW	460 Kg - 1014 lbs
PERFORMANCE	
Max speed VNE	194 Km/h - 104 kt
Cruise speed	160 Km/h - 86 kt
Vertical speed	7 m/s - 1400 ft/min
Service ceiling	3050 m - 10000 ft
Fuel type	
	Mogas RON 95 E10 / AvGas UL91/UL94
Endurance	2,5 hrs.

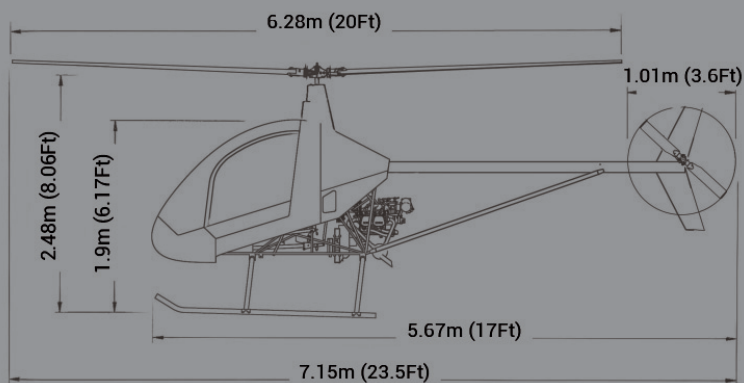

More adrenaline

The **CICARÉ 7BT** is the version of the single-seater that is equipped with the Rotax 914, offering a higher MTOW, service ceiling, and power, thanks to the addition of the turbo.

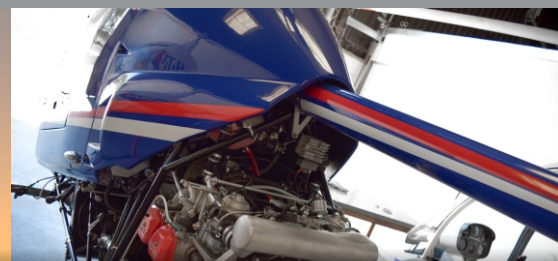

Operators: Argentina, Australia, Brasil Canada, Arab Emirates, Eslovakia, USA, Taiwan, Spain, France, Turkey.