

CICARÉ 7T

Tandem seat ULM helicopter



CICARÉ 7T

TECH SPECS

Seats	2
ENGINE	
Manuf./model	Rotax 914 UL
Type	4 Cyl. boxer
Maximum power	115 HP
WEIGHT	
Empty	280 Kg - 617 lbs
MTOW	460 Kg - 1014 lbs
PERFORMANCE	
Max speed VNE	194 Km/h - 104 kt
Cruise speed	160 Km/h - 86 kt
Vertical speed	7 m/s - 1400 ft/min
Service ceiling	3050 m - 10000 ft
Fuel type	
	Mogas RON 95 E10 / AvGas UL91/UL94
Endurance	2,5 hrs.

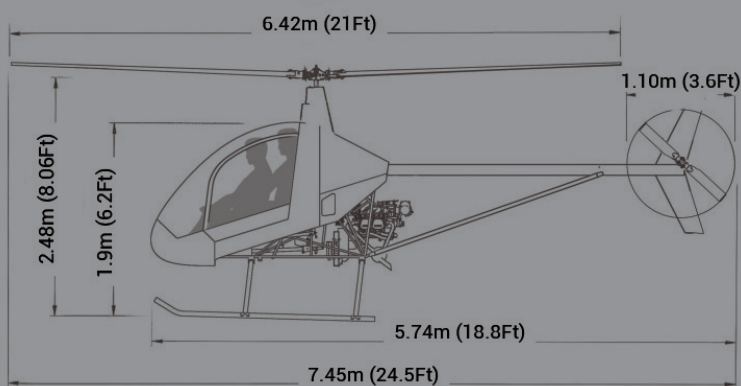

Two seated

The **CICARÉ 7T** is a tandem seat helicopter that has come out as an option to the single seat helicopter 7B. It's equipped with a Rotax 914UL. Approved in France as an ultralight Class 6 helicopter.



Operators: Argentina, Australia, Brasil Canada, Arab Emirates, Eslovakia, USA, Taiwan, Spain, France, Turkey.